

PURLIN HANDRAIL (UNDER SLUNG) INSTALLATION GUIDE

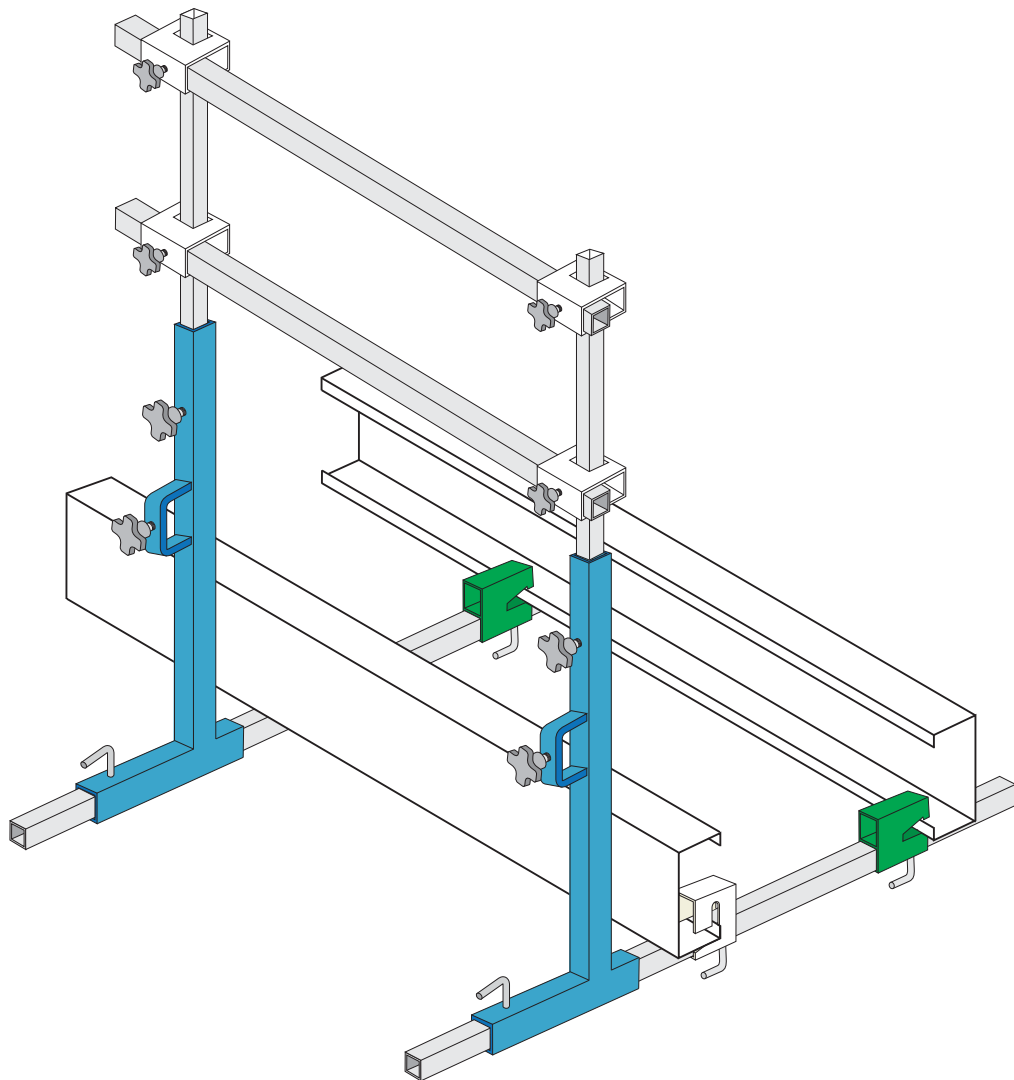

Introduction

The Victorian occupational health and safety act 2004 requires for all people and organizations to ensure a safe and healthy work environment. The Occupational Health and safety prevention of falls compliance code that was updated in Dec 2019, provides practical guidance to all duty holders relating to fall hazards associated with construction work and requires all duty holders to identify all risks that involve the possibility of someone falling more than 2 metres and eliminate all such hazards ,so far as is reasonably practical.

It is also noted in the code that a fall from almost any height including falls from below 2m can result in serious injury or death. It is possible that a number of factors can combine to create a dangerous situation making the hazard identification and risk assessment process essential for work at any height.

An employer's primary duty of care is to eliminate the risk of injury to an employee. The best way of achieving this is before work commences, identifying potential risks and applying risk control measures as set out in the hierarchy of control matrix of the prevention of falls compliance code.

The use of perimeter guardrail is in the second highest control measure available, along with safety mesh and elevated work platforms. Only the possibility of carrying out work on the ground rates higher in the hierarchy than using a perimeter guardrail system. The Aldeck handrail system can be used pre, during or post construction to minimize the risk of people falling from height. The Aldeck handrail system is fully tested and complies with AS 1657-1992 and AS/NZS 4994.1:2009

- The Aldeck handrail system should be erected and dismantled in accordance with legislation under the OH&S act. A thorough risk assessment should be conducted and a safe work procedure applied prior to any work taking place.
- The handrail system should only be installed, modified or dismantled by a competent person, who has read and comprehended the installation guide relevant to the Aldeck hand rail system that they intend to install or dismantle.
- Posts to be installed at a maximum of 3 metres apart
Handrail heights are dictated by the Australian standard and are dependent on the roof pitch
Roof pitches from the horizontal
 - 0 to 10 degrees handrail need to be not less than 900mm high
 - 10 to 35 degrees, the top rail shall be located at an effective height of not less than 900mm
Above the point where a person could stand inside and adjacent to the edge protection on the sloping roof. This shall be not less than 300mm from the back of the fascia or outer edge of the truss or rafter where there is no fascia.
 - Where mid rails are used, the nominal clear distance between rails shall not exceed 450mm. The nominal clear distance between a mid-rail and a toe board or bottom rail shall not exceed 275mm.
 - Rails intersecting at corners of edge protection shall be securely connected to each other or to a post. The connection shall be one rail immediately above the other.
 - In any section of edge protection, the rails shall be nominally parallel.

Introduction cont.

- Where the slope of the roof exceeds 35 degrees, the roof according to the code of practice (prevention of falls 2019) is an inappropriate surface to stand on. Perimeter guard rails and catchment platforms are inappropriate measures to protect workers on a steeply sloping roof. In these circumstances, roof workers need a system to prevent sliding and to prevent falls from the perimeter, comprising one or more of the following
 - Elevated work platform
 - A work positioning system, such as a travel restraint or industrial rope system
 - A scaffold platform, located at the roof edge
 - A roof ladder

FIGURE 1 EFFECTIVE HEIGHT OF A GUARDRAIL

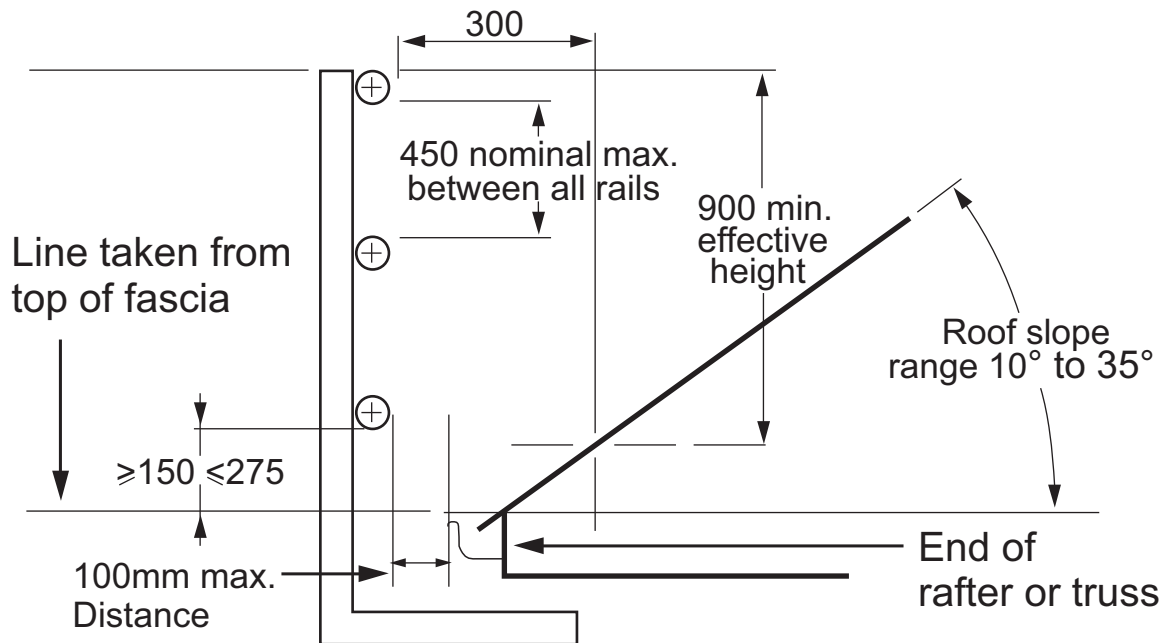

NOTE: Infill and toeboards are not shown for clarity.

DIMENSIONS IN MILLIMETRES

IMPORTANT

It is important that the structure to which the temporary edge protection is to be attached can support the forces that may be applied when the edge protection restrains a person from falling from the edge.

Purlin Handrail (Under Slung)

Aldeck

STEP 1

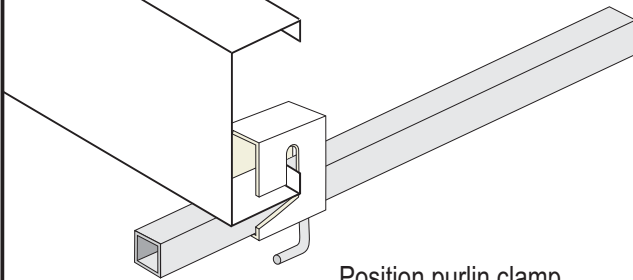

Position purlin clamp onto perimeter purlin.
Slide the support bar through the purlin clamp.

STEP 2

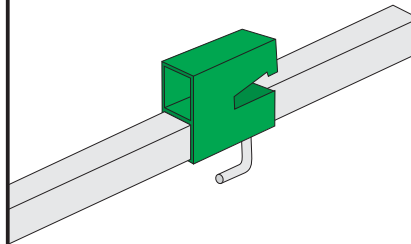

Attach the purlin hook bracket onto the support bar and lock in the required position.

STEP 3

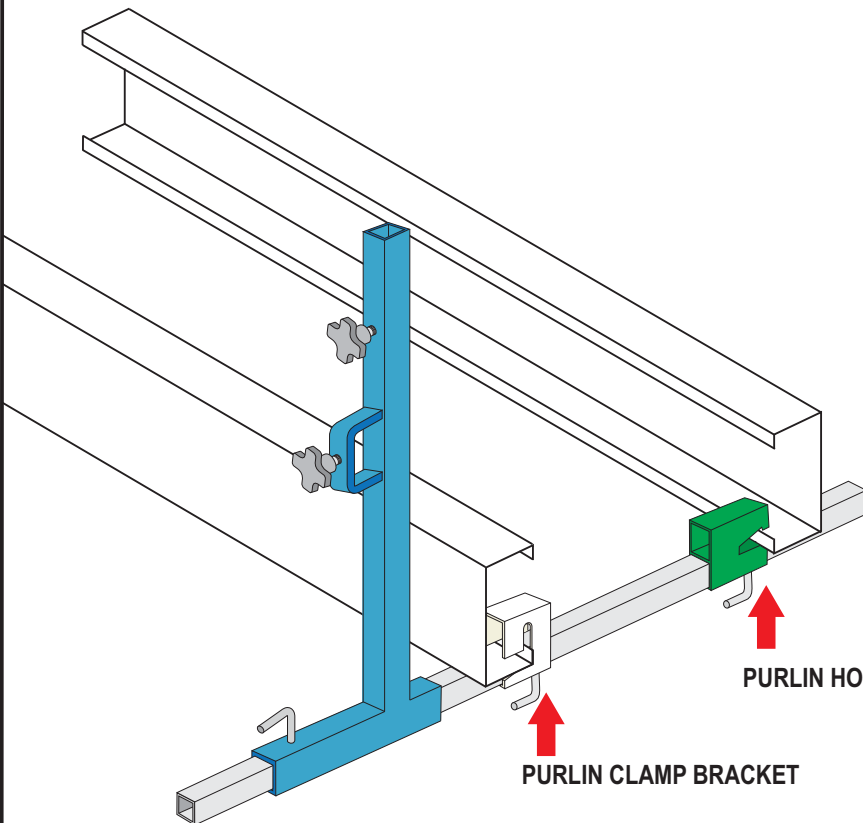

Continue to slide the support bar through purlin clamp and wedge hook bracket into 2nd purlin.

Lock purlin clamp and support bar into position via locking handle on purlin clamp.

Purlin Handrail (Under Slung)

Aldeck

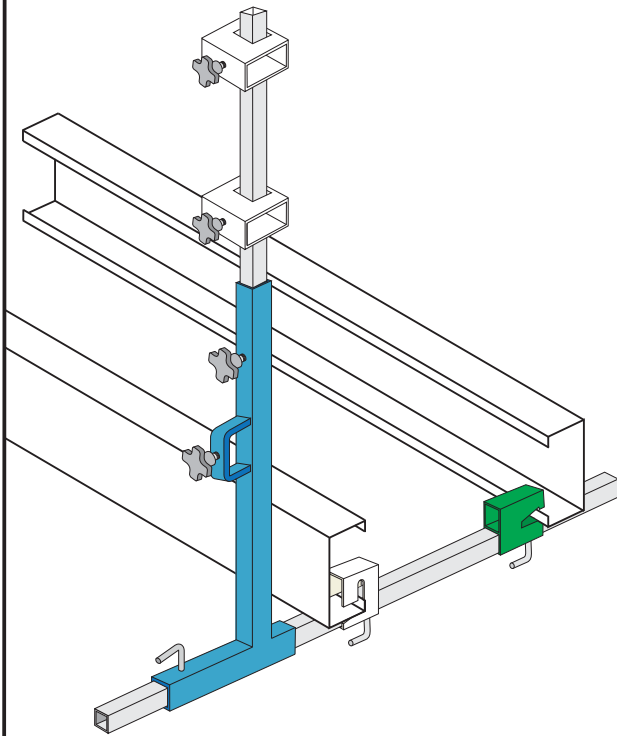

STEP 4

Slide top post into bottom post and lock into position via locking handle.

Remember maximum gap in between rails is 450 mm and minimum height of handrail has to be 900mm above feet level.

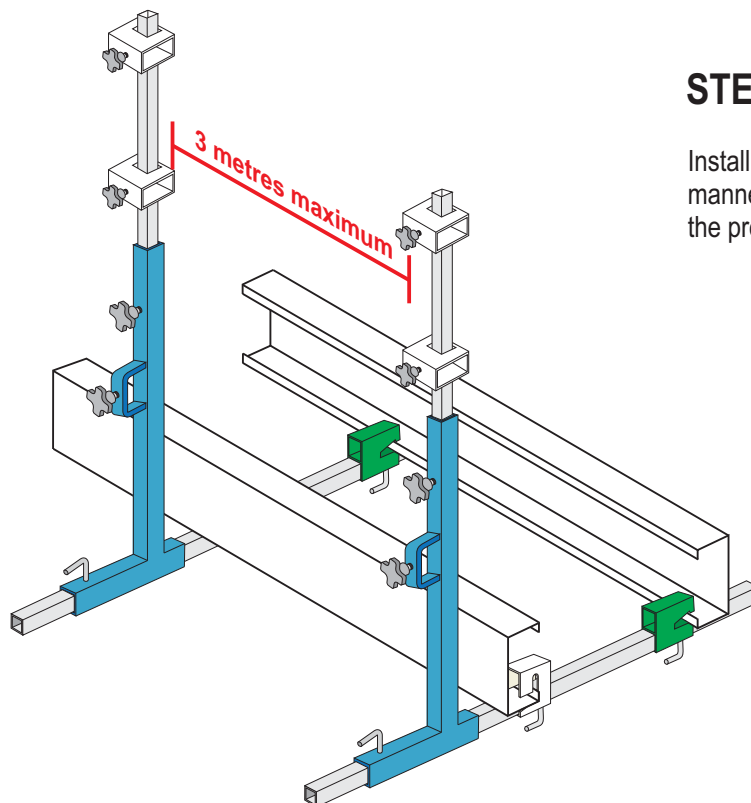

STEP 5

Install next post in the same manner, no more than 3m from the previous post installed.

Purlin Handrail (Under Slung)

Aldeck

STEP 6

Slide handrails into post supports and lock into position via locking handles on posts.

Join rails between posts via use of handrail joiners or corner brackets.

Repeat Steps 1 to 6 until installation is completed.

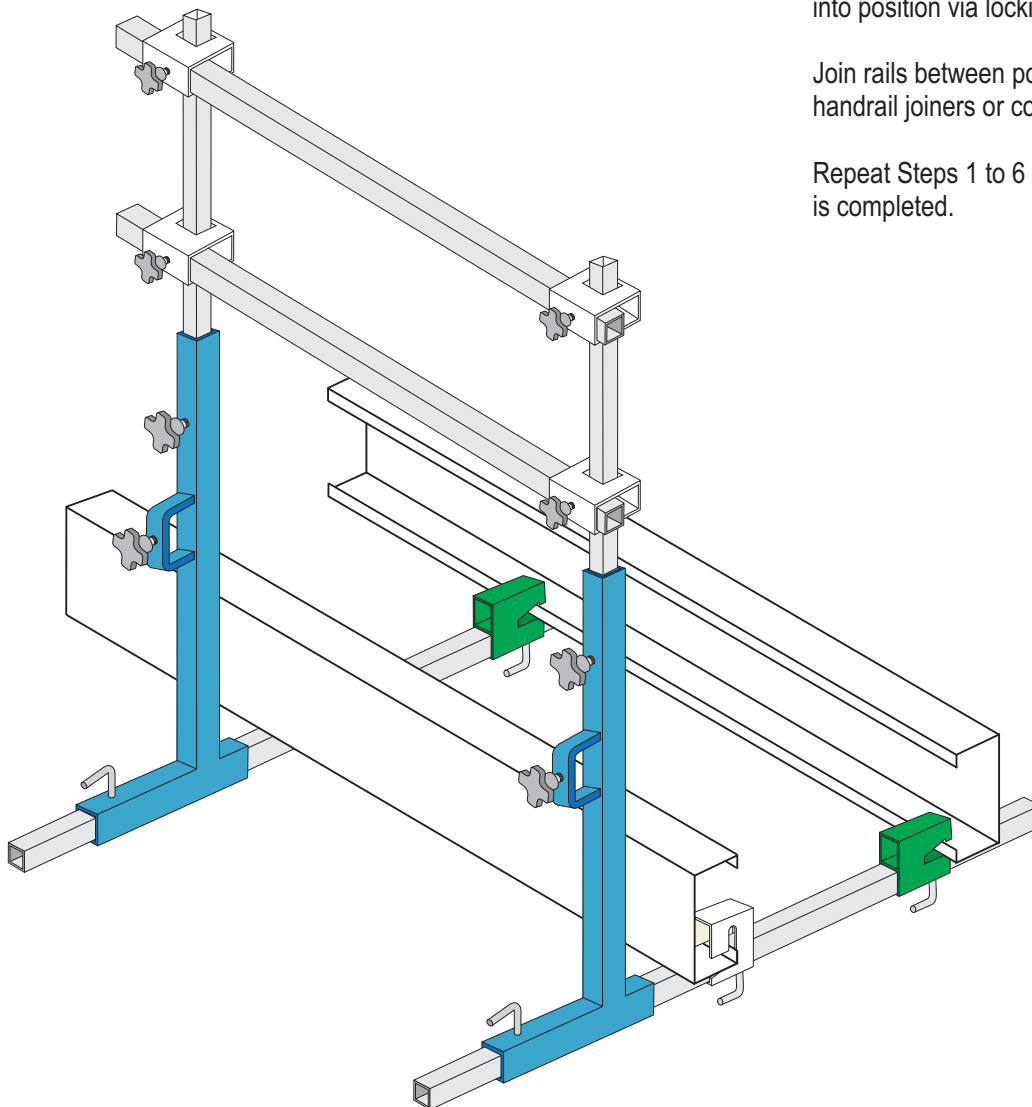

Adjustable Handrail Corner

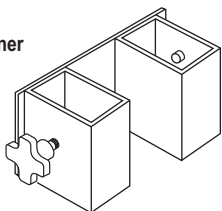

Handrail Joiners

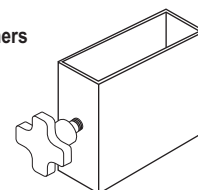

When installing or dismantling, this work must be in accordance with state legislation under the OH&S act.